

Service Manual

THE FISHER®

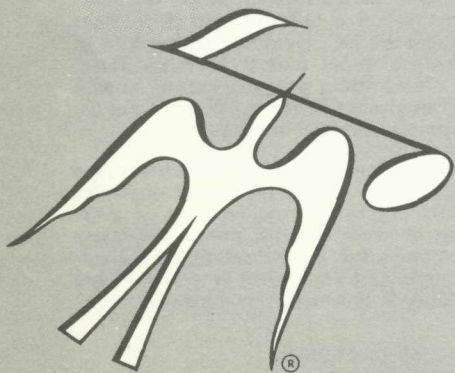
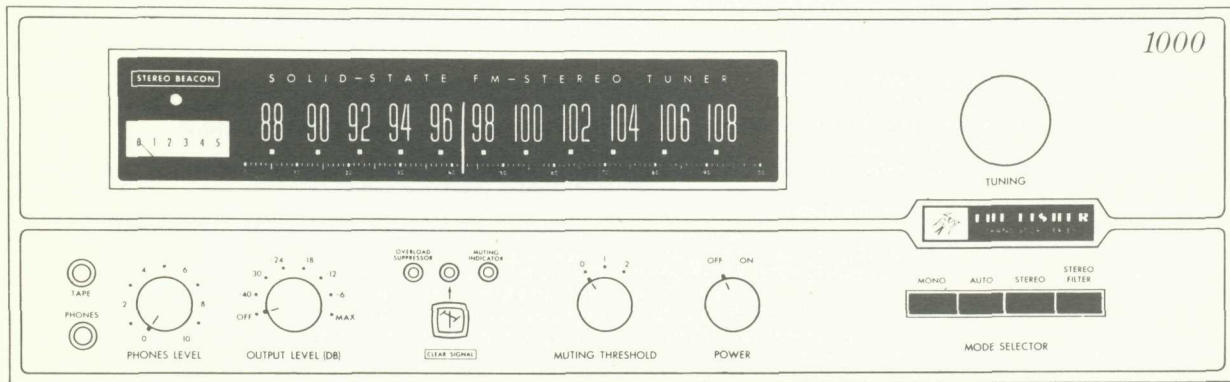

TFM-1000

AND
 FMR-2 - RACK MOUNTED VERSION
 CHASSIS SERIAL NUMBERS
 BEGINNING 10001

PRICE \$1.00

FISHER RADIO CORPORATION • LONG ISLAND CITY 1 • NEW YORK

(c) www.fisherconsoles.com

CAUTION: This is a FISHER precision high-fidelity instrument. It should be serviced only by qualified personnel — trained in the repair of transistor equipment and printed circuitry.

TEST EQUIPMENT REQUIRED

The following are needed to completely test and align modern high-fidelity instruments such as amplifiers, tuners and receivers.

Vacuum-Tube Voltohmmeter (100-mV DC scale)	10.7-MHz Sweep Generator
Audio Vacuum-Tube Voltmeter (10-mV AC scale)	455-kHz Sweep Generator
Oscilloscope (Flat to 100 kHz Minimum)	Line Voltage Autotransformer or Voltage Regulator
Audio (Sine-Wave) Generator	2 — Load Resistors, 4 or 8 Ohm, 50 Watt
Intermodulation Distortion Analyzer	2 — Full Range Speakers for Listening Tests
Harmonic Distortion Analyzer	Stereo Source — Turntable or Tape Recorder for Listening Tests
AM/FM Signal Generator	Soldering Iron with Small Tip Fully Insulated from Power Line
Multiplex Generator (preferably with RF output — FISHER Model 300 or equal)	Suction Desoldering Tool

PRECAUTIONS

Many of these items are included just as a reminder—they are normal procedures for experienced technicians. Shortcuts can be taken but often they cause additional damage — to transistors, circuit components or the printed-circuit board.

Soldering—A well-tinned, hot, clean soldering iron tip will make it easier to solder without damage to the printed-circuit board or the many circuit components mounted on it. It is not the wattage of the iron that counts — it is the heat available at the tip. Some 50-watt irons reach temperatures of 1,000° F — others will hardly melt solder. Small-diameter tips should be used for single solder connections — larger pyramid and chisel tips are needed for larger areas.

- When removing defective resistors, capacitors, etc., the leads should be cut as close to the body of the circuit component as possible. (If the part is not being returned for in-warranty factory replacement it may be cut in half — with diagonal-cutting pliers — to make removal easier.)

- Special de-soldering tips are made for unsoldering multiple-terminal units like IF transformers and electrolytic capacitors. By unsoldering all terminals at the same time the part can be removed with little chance of breaking the printed-circuit board.

- Always disconnect the chassis from the power line when soldering. Turning the power switch OFF is not enough. Power-line leakage paths, through the heating element, can destroy transistors.

Transistors—Never attempt to do any work on the transistor amplifiers without first disconnecting the AC linecord and waiting until the power supply filter-capacitors have discharged.

- Guard against shorts — it takes only an instant for a base-to-collector short to destroy that transistor and possibly others direct-coupled to it. [In the time it takes for a dropped machine screw, washer or even the screwdriver, to glance off a pair of socket terminals (or between a terminal and the chassis) a transistor can be ruined.]

- DO NOT bias the base of any transistor to, or near, the same voltage applied to its collector.

- DO NOT use an ohmmeter for testing transistors. The voltage applied through the test probes may be higher than the base-emitter breakdown voltage of the transistor.

Output Stage and Driver — Replacements for output and

driver transistors, if necessary, must be made from the same beta group as the original type. The beta group is indicated by a colored dot on the mounting flange of the transistor. Be sure to include this information, when ordering replacement transistors.

- If one output transistor burns out (open or shorts), always remove ALL output transistors in that channel and check the bias adjustment, the control and other parts in the network with an ohmmeter before inserting a new transistor. All output transistors in one channel will be destroyed if the base-biasing circuit is open on the emitter end.

- When mounting a replacement power transistor be sure the bottom of the flange, the mica insulator and the surface of the heat sink are free of foreign matter. Dust and grit can prevent perfect contact reducing heat transfer to the heat sink. Metallic particles can puncture the insulator and cause shorts — ruining the transistor.

- Silicone grease must be used between the transistor and the mica insulator and between the mica and the heat sink for best heat conduction. (Use Dow-Corning DC-3 or C20194 or equivalent compounds made for power transistor heat conduction.)

- Use care when making connections to speakers and output terminals. Any frayed wire ends can cause shorts that may burn out the output transistors — they are direct-coupled to the speakers. To reduce the possibility of shorts at the speakers, lugs should be used on the exposed ends or at least the ends of the stranded wires should be tinned to prevent frayed wire ends. The current in the speakers and output circuitry is quite high. Poor contacts or small size wire can cause power losses in the speaker system. Use 14 or 16 AWG for long runs of speaker wiring.

Voltage Measurements—Voltage measurements are made with the line voltage adjusted to 117 volts and all readings are $\pm 10\%$. All voltages are DC, measured with a VTVM to ground, with no signal input unless otherwise noted. indicates 1-kHz audio voltages, measured with an audio AC VTVM to ground at various points from the phono input to the power amplifier output.

Alignment Procedures — Replacement of transistors and components in the front end, IF amplifier and multiplex decoder will normally not require realignment of these circuits. Realignment of these circuits, unless absolutely necessary, is not recommended. Do not attempt a realignment unless the required test equipment is available and the alignment procedure is thoroughly understood.

BECAUSE ITS PRODUCTS ARE SUBJECT TO CONTINUOUS IMPROVEMENT, FISHER RADIO CORPORATION RESERVES THE RIGHT TO MODIFY ANY DESIGN OR SPECIFICATION WITHOUT NOTICE AND WITHOUT INCURRING ANY OBLIGATION.

WARNING

Remove the FMR-2 rack-mounted unit from the rack before performing any servicing by unscrewing the four front panel machine screws and disconnecting all cables.

SERVICE PROCEDURES

DIAL STRINGING PROCEDURES

- Remove dial pointer
 - Lift out left dial glass lamp and remove screw holding left side of dial glass panel.
 - Remove two screws holding right side of dial glass panel.
 - Pull dial glass panel towards left and tilt the panel down as far as the leads allow.
 - Rotate the tuning capacitor drive drum to its maximum counter-clockwise position.
 - Tie end of dial cord to the end of small spring A. Fasten spring to ear inside the drive drum (Figure 1).
 - Run the dial cord through the slot in the rim of the drive drum and set in the underside of groove 1 (side view).
 - Pull dial cord taut and wrap 1½ turns around the flywheel shaft.
 - Rotate the tuning capacitor drive drum to its maximum clockwise position, allowing the dial cord to follow the grooves in the drive drum (Figure 2). Keep the dial cord taut during this procedure.
 - Guide the dial cord over the top of the drive drum and place it in groove 3 (top view).
 - Run the dial cord through the slot in the drive drum and bring it under and around the beveled washer. Pull the dial cord taut and tighten the machine screw to hold the dial cord under the washer.
 - Rotate tuning capacitor drive drum to its maximum counter-clockwise position.
 - Run loose end of dial cord out through the slot in the drive drum and place it in groove 3 (Figure 3). Guide the dial cord through pulleys A and B.
 - Rotate the tuning capacitor drive drum to its maximum clockwise position. Keep the dial cord taut during this procedure.
 - Guide the dial cord under the drive drum into groove 5 (Figure 4). Bring the dial cord up and around groove 6 and into the slot in the drive drum.
- NOTE: Check that there is an empty groove between this turn and the next to last turn of dial cord on the drum.
- Loosen the machine screw. Pull the dial cord taut until adjusting spring B stretches open. Place the cord under the beveled washer and tighten the machine screw.
- CAUTION: Do not disturb dial cord already placed under the washer.
- Replace the dial glass panel using the first three steps in reverse order.
 - Replace the dial pointer on the top of the dial glass panel.
 - Place dial cord under and over the rear of dial pointer (see detail drawing).
- NOTE: Nylon pulleys generally do not need lubrication. If roughness or noise occurs during tuning, apply Versilube G300 or equivalent silicon grease to the end of the flywheel shaft.

REPLACING METER LAMP

- Disconnect AC power cord.
- Remove two screws which hold the meter protecting cover to the chassis bracket.
- Gently push in on the lamp and turn it counterclockwise to remove. Remove the metal lamp shade and place it on the new lamp in the same position. Place the new lamp in the socket, push in gently and turn it clockwise to lock it in place.
- Replace the meter protecting cover and secure with the two screws removed previously.

REPLACING STEREO BEACON LAMP

- Disconnect AC power cord.
- Remove two screws which hold the meter protecting cover to the chassis bracket.
- Pry nylon lamp holder from the lamp mount. Unsolder the leads from the lamp holder. Solder leads to rear terminals on the new lamp holder. Place new lamp holder in the mount.
- Replace the meter protecting cover and secure with the two screws removed previously.

REPLACING DIAL LAMPS

- Disconnect AC power cord.
- On the FMR-2 rack-mounted unit only, remove the four machine screws that hold the front-panel handles and remove the handles.
- Gently pull all knobs off the front panel control shafts. Remove the hex nuts from the control shafts and lift off the front panel.
- Snap out the defective lamp from the spring clip. Place the new lamp in the socket making certain that the unpainted side of the lamp faces the edge of the dial glass.
- Replace the front panel and secure with the hex nuts removed previously. Replace the knobs on the control shafts.
- On the FMR-2 unit only, replace the front panel handles and secure with the four screws removed previously.

CLEANING DIAL GLASS

- Disconnect AC power cord.
- On the FMR-2 rack-mounted unit only, remove the four machine screws that hold the front panel handles and remove the handles.
- Gently pull all knobs off the front panel control shafts. Remove the hex nuts from the control shafts and lift off the front panel.
- Remove the two foam cushion strips located at the ends of the dial glass.
- Loosen the screws that hold the retaining clips to the dial glass. Swing the clips aside and lift off the dial glass.
- Remove dust with a dry cloth. If you wish to clean more thoroughly, use a soap-and-water solution only, any stronger cleaning agent may damage the markings on the glass.
- Replace the dial glass and position it down and towards the left of the chassis front. Swing the retaining clips back into place and tighten the retaining-clip screws. Replace the foam cushion strips.
- Replace the front panel and secure with the hex nuts removed previously. Replace the knobs on the control shafts.
- On the FMR-2 unit only, replace the front panel handles and secure with the four screws removed previously.

REPLACING DIAL POINTER LIGHT

- Disconnect AC power cord.
- Remove the front panel and dial glass as described in the preceding paragraph.
- Remove the lamp wires from the holding clip on the rear of the pointer base and from the two clips on the top of the chassis.
- Slide the dial pointer assembly directly downward to release it from the pointer base.
- Slide the new dial pointer assembly upward, while pressing downward on the pointer base, until the tab on the pointer mates with the slot in the pointer base.
- Twist the lamp wires together and place them under the holding clip on the rear of the pointer base. Do not leave any slack in the wire above the pointer.
- Connect the ends of the two wires to the clips on the top of the chassis.
- Replace the dial glass and front panel as described in the preceding paragraph.

CLEANING FRONT PANEL

WARNING: Use only plain lukewarm water and a freshly laundered, soft lint-free cloth to clean the front control panel.

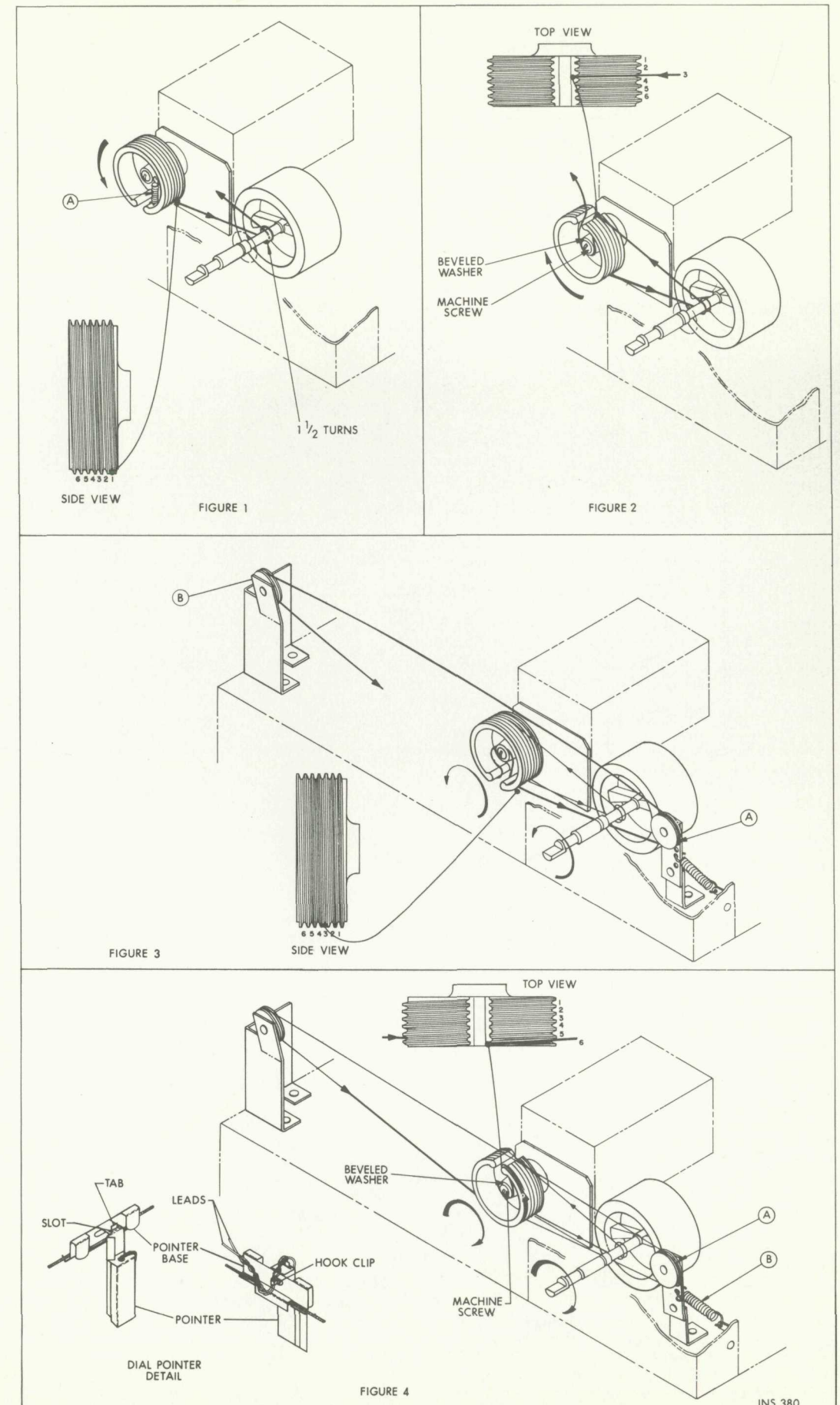

SERVICE PROCEDURES

FRONT END ALIGNMENT

NOTE: IF alignment must be performed before starting this procedure.

- Set TUNING dial pointer to zero (0) calibration mark on the logging scale. If the dial pointer does not coincide with the 0 at the extreme end of the knob rotation, reposition the pointer assembly on the dial cord and cement the pointer in place to prevent slippage.
- Connect DC VTVM to positive side of diode CR2.
- Connect an RF generator to the 300Ω antenna terminals. Use a 120-ohm composition resistor in series with each lead from the generator—see Figure 1. Set ANTENNAS SELECTOR switch to 300 OHM position.
- Set RF generator frequency and TUNING dial pointer to 90 MHz. DO NOT USE MODULATION (AM or FM) and set the generator output for a reading of +0.5 VDC on DC VTVM.
- Align oscillator coil (L755) core first—then align the RF coils (L754, L753, L752) for maximum reading on DC VTVM.
- Set RF generator frequency and TUNING dial pointer to 106 MHz.
- Adjust oscillator trimmer (C769) first—then adjust the RF trimmers (C767, C761, C755) for maximum reading on DC VTVM.
- Repeat alignment several times until accurate dial calibration and maximum gain are obtained.
- Set RF generator frequency and TUNING dial pointer to 98 MHz. Check calibration and DC voltage. Calibration should be ±1 dial pointer width and DC voltage should be within ±10% of readings at 90 and 106 MHz.

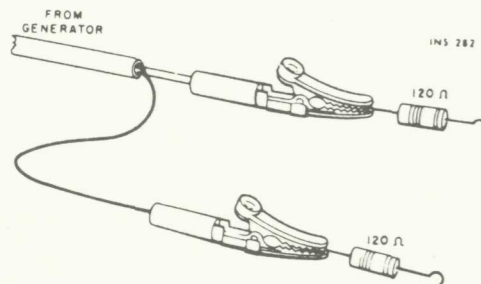

FIGURE 1. CONNECTIONS TO PROVIDE 300-OHM GENERATOR OUTPUT IMPEDENCE. MATCHING RESISTORS REDUCE GENERATOR VOLTAGE BY HALF AT THE ANTENNA TERMINALS.

IF ALIGNMENT

- Remove transistor Q307 from the IF board.
 - Connect detector doubler circuit shown in Figure 2 between probe of DC VTVM and TP301 on the IF board.
 - Connect FM generator, set for 10.7 MHz with no modulation, to TP751 on the front end.
- NOTE:** Keep the generator output as low as possible during all adjustments.
- Adjust top and bottom cores of Z751, Z301 and Z302 for maximum DC VTVM reading.
 - Connect detector doubler circuit between probe of DC VTVM and TP302 on the IF board.
 - Turn bottom core of Z303 completely counterclockwise.
 - Adjust top core of Z303 to the point of the first maximum meter indication from the top of the coil. Adjust core for maximum reading on DC VTVM.

- Adjust bottom core of Z303 to the point of the first minimum meter indication from the bottom of the coil. Adjust core for minimum reading on DC VTVM.
- Connect detector doubler circuit between probe of DC VTVM and TP303 on the IF board.
- Adjust Z304 for maximum reading on DC VTVM.
- Connect DC VTVM to connection 3G on the IF board.
- Adjust Z305 for maximum reading on DC VTVM.
- Connect DC VTVM to positive side of diode CR2.
- Increase generator output for a reading of +0.5 VDC on DC VTVM. Adjust Z1 for maximum reading on DC VTVM.
- Insert transistor Q307 on the IF board.

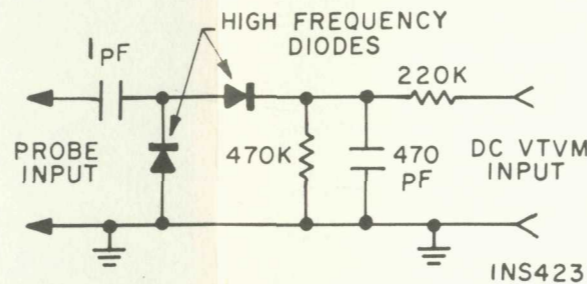

FIGURE 2. PROBE DETECTOR CIRCUIT.

AGC ADJUSTMENT

- Connect FM generator to the 300Ω antenna terminals. Use a 120-ohm composition resistor in series with each lead from the generator—see Figure 1. Set ANTENNAS SELECTOR switch to 300 OHM position.
- Set FM generator frequency and TUNING dial pointer to 98 MHz. Set FM generator output to 100 uV, ±22.5 kHz deviation at 400 Hz.
- Connect AC VTVM through a high-frequency AC probe to connection 9A on the limiter detector board.
- Adjust AGC Adjust Pot. R331 on the IF board for a meter reading of exactly 260 mV RMS.
- Increase generator output up to 100 mV. Observe reading on meter. Meter reading should not change from 260 mV as the generator output is varied.

TUNING METER ADJUSTMENT

- Connect FM generator to the 300Ω antenna terminals. Use a 120-ohm composition resistor in series with each lead from the generator—see Figure 1. Set ANTENNAS SELECTOR switch to 300 OHM position.
- Set FM generator frequency and TUNING dial pointer to 98 MHz. Set FM generator output to 100 uV, ±22.5 kHz deviation at 400 Hz.
- Adjust Tuning Meter Adjust 100 uV Pot. R9A for reading on tuning meter of 2.5.
- Reduce generator output for reading on tuning meter of 1. Press CLEAR SIGNAL pushbutton switch, CLEAR SIGNAL lamp should light slightly.

- Increase generator output to 100 mV. Adjust Tuning Meter Adjust 100 mV Pot. R9B for reading on tuning meter of 4.

MUTING ADJUSTMENT

- Connect FM generator to the 300Ω antenna terminals. Use a 120-ohm composition resistor in series with each lead from the generator—see Figure 1. Set ANTENNAS SELECTOR switch to 300 OHM position.
- Set FM generator frequency and TUNING dial pointer to 98 MHz. Set FM generator output to 8 uV, ±22.5 kHz deviation at 400 Hz.
- Connect oscilloscope to LEFT TAPE output jack.
- Set MUTING THRESHOLD switch to position 1 and adjust Muting Adjust 8 uV Pot. R9C until audio output is observed on scope. Vary generator output from 4 uV to 200 mV; audio output on scope should not change. Reduce generator output to 0.1 uV; audio signal should no longer be present on scope.
- Set MUTING THRESHOLD switch to position 2.
- Increase generator output to 50 uV. Adjust Muting Adjust 50 uV Pot. R9D until audio output is observed on scope. Vary generator output from 4 uV to 200 mV; audio output on scope should not change.
- Connect oscilloscope to RIGHT TAPE output jack. Check muting action with 8 uV and 50 uV generator outputs.

DYNAMIC ATTENUATOR ADJUSTMENT

- Connect FM generator to the 300Ω antenna terminals. Use a 120-ohm composition resistor in series with each lead from the generator—see Figure 1. Set ANTENNAS SELECTOR switch to 300 OHM position.
- Set FM generator frequency and TUNING dial pointer to 98 MHz. Set FM generator output to 3 uV, ±75 kHz deviation at 400 Hz.
- Set MUTING THRESHOLD switch to 0 position and MODE SELECTOR pushbutton switch to MONO.
- Connect oscilloscope to LEFT MAIN output jack. Audio output should be observed on scope.
- Connect jumper from junction of coil L3 and capacitor C2 to chassis ground; audio signal should no longer be present on scope.
- Increase generator output to 90 to 120 uV; audio output should be observed on scope.

LIMITER DETECTOR ADJUSTMENT

- Disconnect lead going to connection 9A on the limiter detector board. Connect AM generator, set for 10.7 MHz, to connection 9A. Adjust generator for 260 mV output with 30% modulation.
- Disconnect lead going to connection 9K on the limiter detector board. Connect AC VTVM to connection 9K.
- Adjust Limiter Adjust Pot. R 919 for minimum reading on AC VTVM. AC VTVM meter should read below -60 db from reference of 2 volts.
- Disconnect AM generator and connect sweep generator to connection 9A.
- Disconnect AC VTVM and connect oscilloscope to connection 9K. Straight-sloped line should be observed on scope.
- Disconnect sweep generator and oscilloscope. Reconnect leads to connections 9A and 9K.

SERVICE PROCEDURES

MULTIPLEX ALIGNMENT

Two methods of aligning the multiplex decoder are given. The preferred procedure uses a multiplex generator with RF and 19 kHz outputs and with 1 kHz modulation, such as the Fisher Model 300 Multiplex Generator. This is the better method of alignment since the front end and IF stages are also checked through the use of this procedure. An alternate procedure for use with multiplex generators not having an RF output is also given.

PREFERRED ALIGNMENT PROCEDURE

Set MODE SELECTOR to AUTO and MUTING THRESHOLD switch to 0.

- Connect multiplex generator to the 300Ω antenna terminals. Use two 120-ohm composition resistors in series with the generator leads.
- Follow procedures given in Table 1 below.

NOTE: Check the alignment of the IF amplifier before aligning the MPX decoder. Poor IF alignment can make proper multiplex adjustment impossible.

ALTERNATE ALIGNMENT PROCEDURE

Set MODE SELECTOR to AUTO and MUTING THRESHOLD switch to 0.

- Disconnect lead going to connection 4C on the multiplex board. Connect multiplex generator to connection 4C.
- Follow procedures given in Table 2 below.
- After alignment, disconnect generator and reconnect lead coming from connection 9K on the limiter detector to connection 4C on the multiplex board.

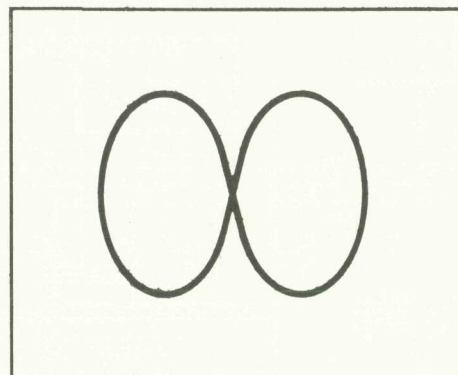

FIGURE 1. LISSAJOUS PATTERN FOR MPX ALIGNMENT.

REPLACING MUTING INDICATOR

- Disconnect AC power cord.
- Remove five screws which hold bottom cover to chassis and lift off the cover.
- Remove two screws which hold CLEAR SIGNAL switch bracket to front of chassis. Tilt the bracket back as far as the leads allow.
- Loosen screw holding MUTING INDICATOR lamp bracket. Twist bracket upward until it is clear of the adjoining lamp mount.
- Gently push in on the lamp and turn it counterclockwise to remove. Place the new lamp in the socket, push in gently and turn it clockwise to lock it in place.
- Twist the lamp bracket back to its original position and tighten mounting screw.
- Replace CLEAR SIGNAL switch bracket and secure with the two screws removed previously.
- Replace bottom cover and secure with the five screws removed previously.

REPLACING CLEAR SIGNAL AND OVERLOAD SUPPRESSOR LAMPS

- Disconnect AC power cord.
- Remove five screws which hold bottom cover to chassis and lift off the cover.
- Remove two screws which hold CLEAR SIGNAL switch bracket to front of chassis. Tilt the bracket back as far as the leads allow.
- Pry nylon lamp holder from lamp mount. Unsolder the leads from lamp holder. Solder leads to rear terminals on the new lamp holder. Place new lamp holder in mount.
- Replace CLEAR SIGNAL switch bracket and secure with two screws removed previously.
- Replace bottom cover and secure with the five screws removed previously.

TABLE 1 - MULTIPLEX ALIGNMENT USING RF MULTIPLEX SIGNAL

STEP	GENERATOR MODULATION	RF DEV.	INDICATOR TYPE AND CONNECTION	ALIGNMENT	
				ADJUST	INDICATION
1	76kHz (kc) (connect external audio generator to SCA input of multiplex generator).	±10kHz (kc)	Audio (AC) VTVM input to connection 4L with 10pF capacitor in series with lead.	Z2	Minimum AC VTVM reading.
2	71kHz (kc) (same as above).	±10kHz (kc)	Same as Step 1.	L4	Minimum AC VTVM reading.
3	19kHz (kc) pilot only.	±7.5kHz (kc)	DC VTVM to TP401.	Z401 top & bottom, Z402	Maximum DC VTVM reading.
4	Same as Step 3.	no mod.	DC VTVM to connection 4F.	Trigger Control	Stereo Beacon lights up with 0.8V reading on DC VTVM.
5	Connect portion of 19kHz (kc) generator output to scope horizontal input.	no mod.	Vertical scope input through 1 megohm resistor to TP403; scope set for external sweep	Z403 top	Stable Lissajous pattern 2:1 (Figure 1) as slow moving as possible.
6	Same as Step 5.	no mod.	Same as Step 5.	Z403 bottom	Maximum scope amplitude; adjust Z403 top as necessary for slow moving Lissajous.
7	Composite MPX signal 1kHz (kc) on left channel only.	±75kHz (kc)	Audio (AC) VTVM and scope input to left channel output (connection 4H).	Z402	Maximum audio AC VTVM reading; clean 1kHz (kc) sine wave on scope.
8	Composite MPX signal 1kHz (kc) on right channel only.	±75kHz (kc)	Same as Step 7.	Separation Control	Minimum audio AC VTVM reading—at least 35db below reading in Step 7.
9	Same as Step 8.	±75kHz (kc)	Audio (AC) VTVM and scope input to right channel output (connection 4K).	-	Same audio AC VTVM reading as obtained in Step 7 (±2db); clean 1kHz (kc) sine wave on scope.
10	Same as Step 7.	±75kHz (kc)	Same as Step 9.	-	Minimum audio AC VTVM reading—at least 35 db below reading in Step 9.

TABLE 2 - MULTIPLEX ALIGNMENT USING COMPOSITE MULTIPLEX SIGNAL

STEP	GENERATOR MODULATION	LEVEL (RMS)	INDICATOR TYPE AND CONNECTION	ALIGNMENT	
				ADJUST	INDICATION
1	76kHz (kc).	200mV	Audio (AC) VTVM input to connection 4L with 10pF capacitor in series with lead.	Z2	Minimum AC VTVM reading.
2	71kHz (kc).	200mV	Same as Step 1.	L4	Minimum AC VTVM reading.
3	19kHz (kc) pilot only.	Vary 0 to 50mV	DC VTVM to TP401.	Z401 top & bottom, Z402	Maximum DC VTVM reading.
4	Same as Step 3.	15mV	DC VTVM to connection 4F.	Trigger Control	Stereo Beacon lights up with 0.8V reading on DC VTVM.
5	Connect portion of 19kHz (kc) generator output to scope horizontal input.	Vary 10 to 50mV	Vertical scope input through 1 megohm resistor to TP403; scope set for external sweep.	Z403 top	Stable Lissajous pattern 2:1 (Figure 1) as slow moving as possible.
6	Same as Step 5.	Vary 10 to 50mV	Same as Step 5.	Z403 bottom	Maximum scope amplitude; adjust Z403 top as necessary for slow moving Lissajous.
7	Composite MPX signal 1kHz (kc) on left channel only.	100mV (560mV P-P)	Audio (AC) VTVM and scope input to left channel output (connection 4H).	Z402	Maximum audio AC VTVM reading; clean 1kHz (kc) sine wave on scope.
8	Composite MPX signal 1kHz (kc) on right channel only.	100mV (560mV P-P)	Same as Step 7.	Separation Control	Minimum audio AC VTVM reading—at least 35db below reading in Step 7.
9	Same as Step 8.	100mV (560mV P-P)	Audio (AC) VTVM and scope input to right channel output (connection 4K).	-	Same audio AC VTVM reading as obtained in Step 7 (±2db); clean 1kHz (kc) sine wave on scope.
10	Same as Step 7.	100mV (560mV P-P)	Same as Step 9.	-	Minimum audio AC VTVM reading—at least 35db below reading in Step 9.

FE50D965 FM FRONT END

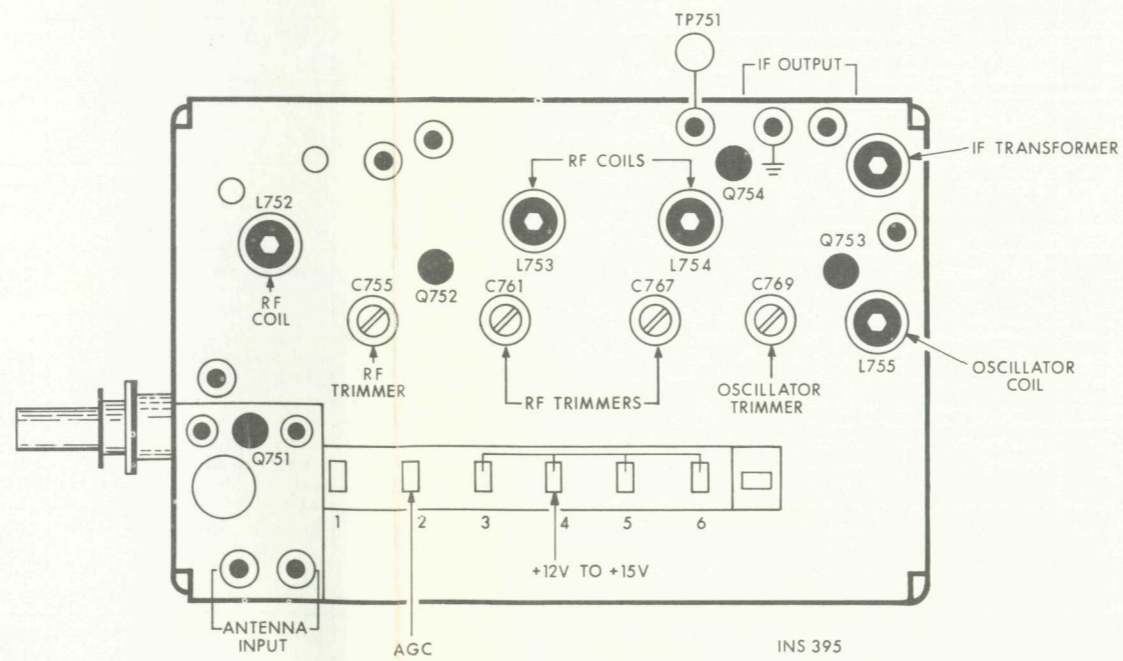
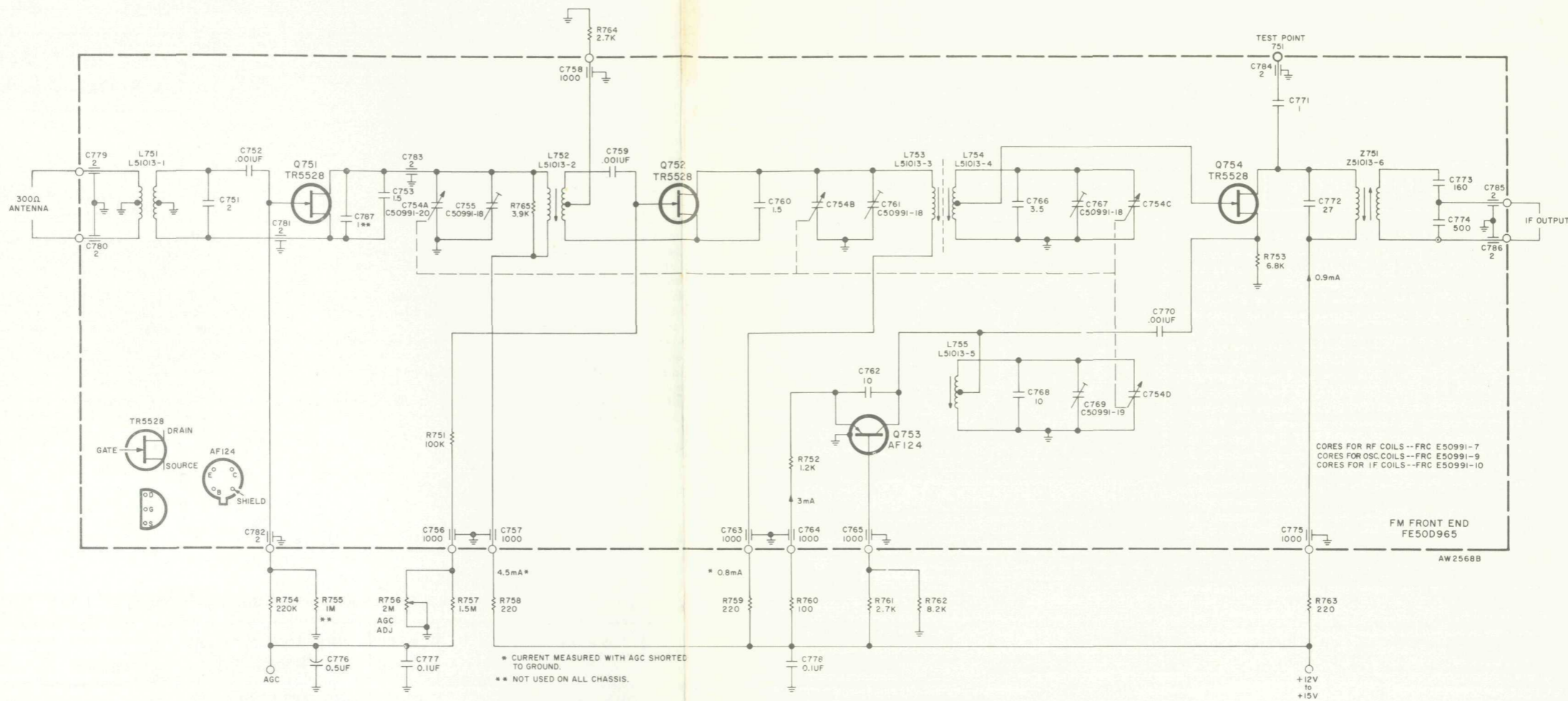

1356 IF AMPLIFIER

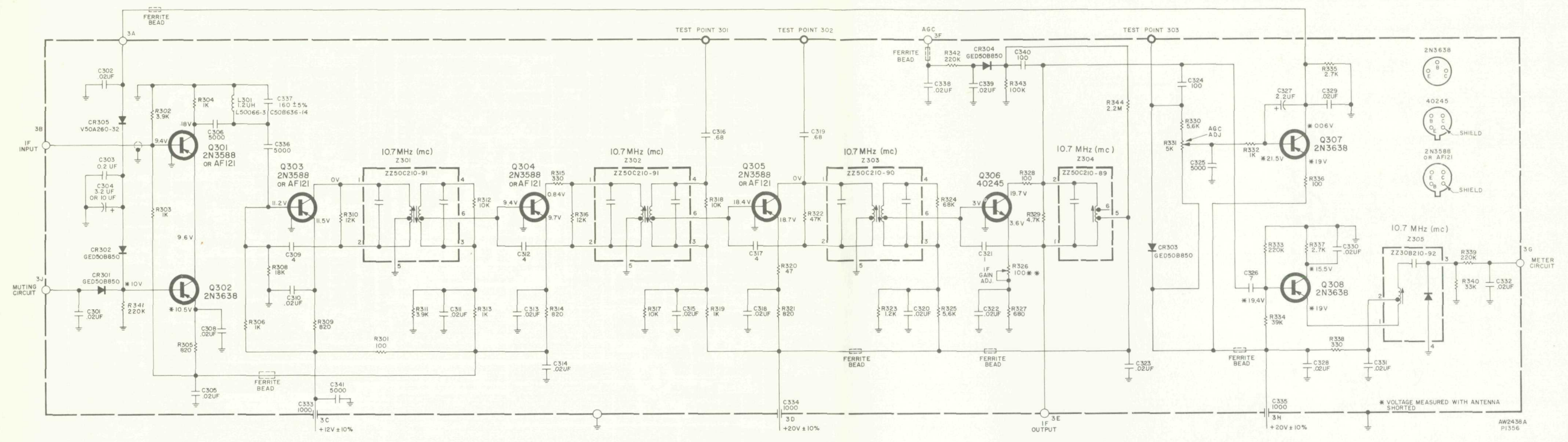

NOTE: * MEASURED WITH ANTENNA SHORTED.
 ** NOT USED ON ALL BOARDS.

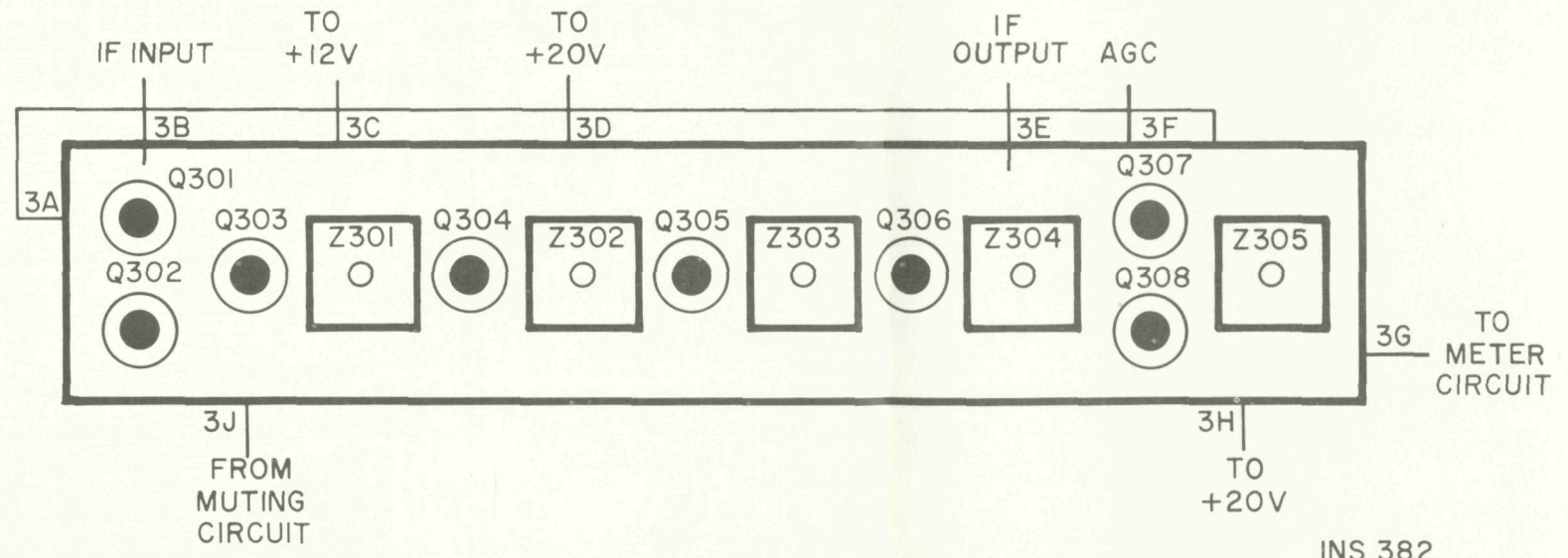

INS 382
 PI356

1471-2 MULTIPLEX DECODER

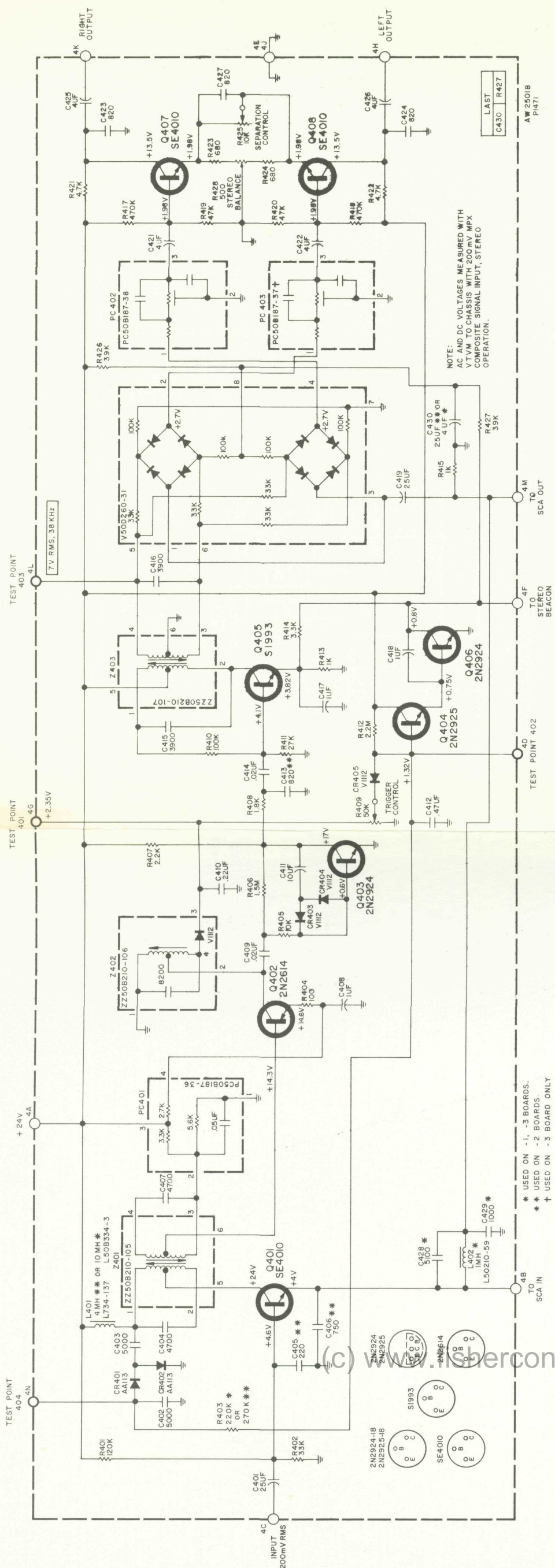

BOARD VIEWED FROM THE COMPONENT SIDE

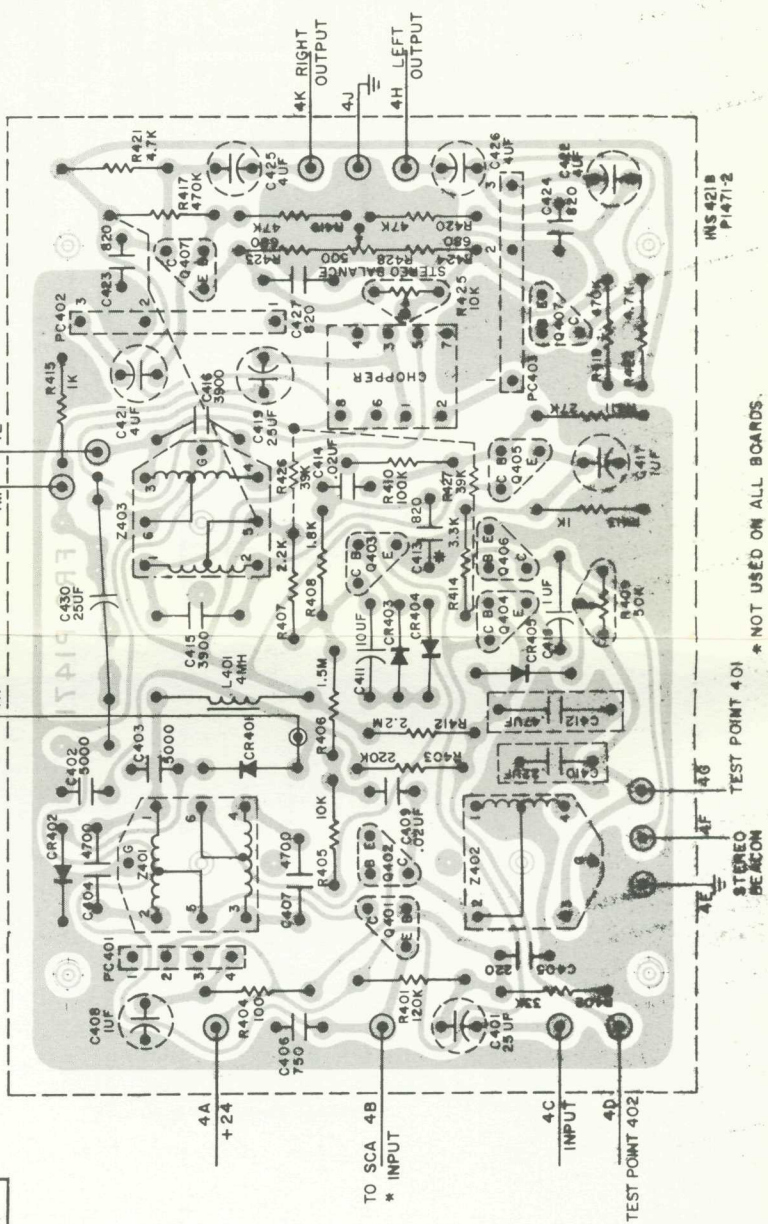

* NOT USED ON ALL BOARDS.

- * USED ON -1, -3 BOARDS.
- ** USED ON -2 BOARDS.
- + USED ON -3 BOARD ONLY

NOTE:
AC AND DC VOLTAGES MEASURED WITH
A CHASSIS WITH 200mV MPX
COMPOSITE SIGNAL INPUT, STEREO
OPERATION.

LAST
C430
R427

1299 LIMITER DETECTOR

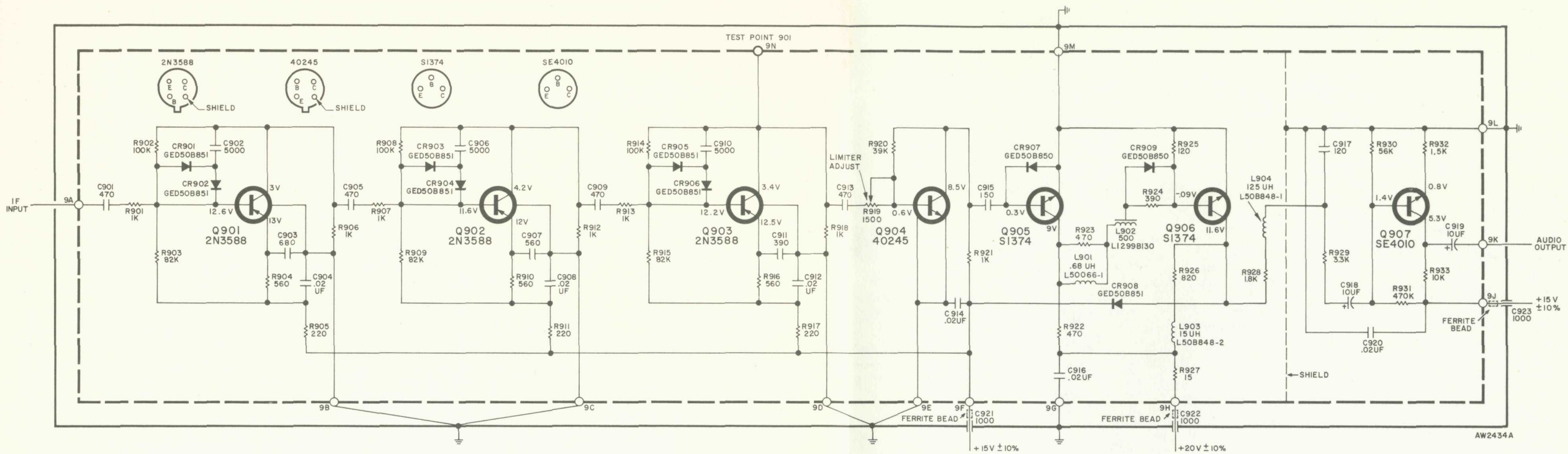

BOARD VIEWED FROM THE COMPONENT SIDE

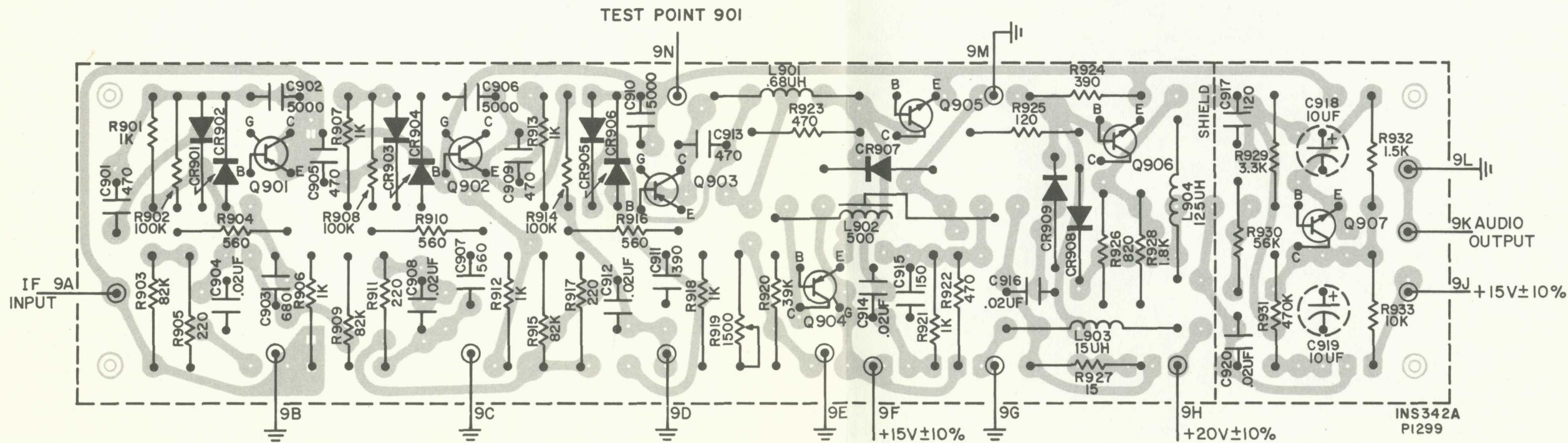

MAIN CHASSIS

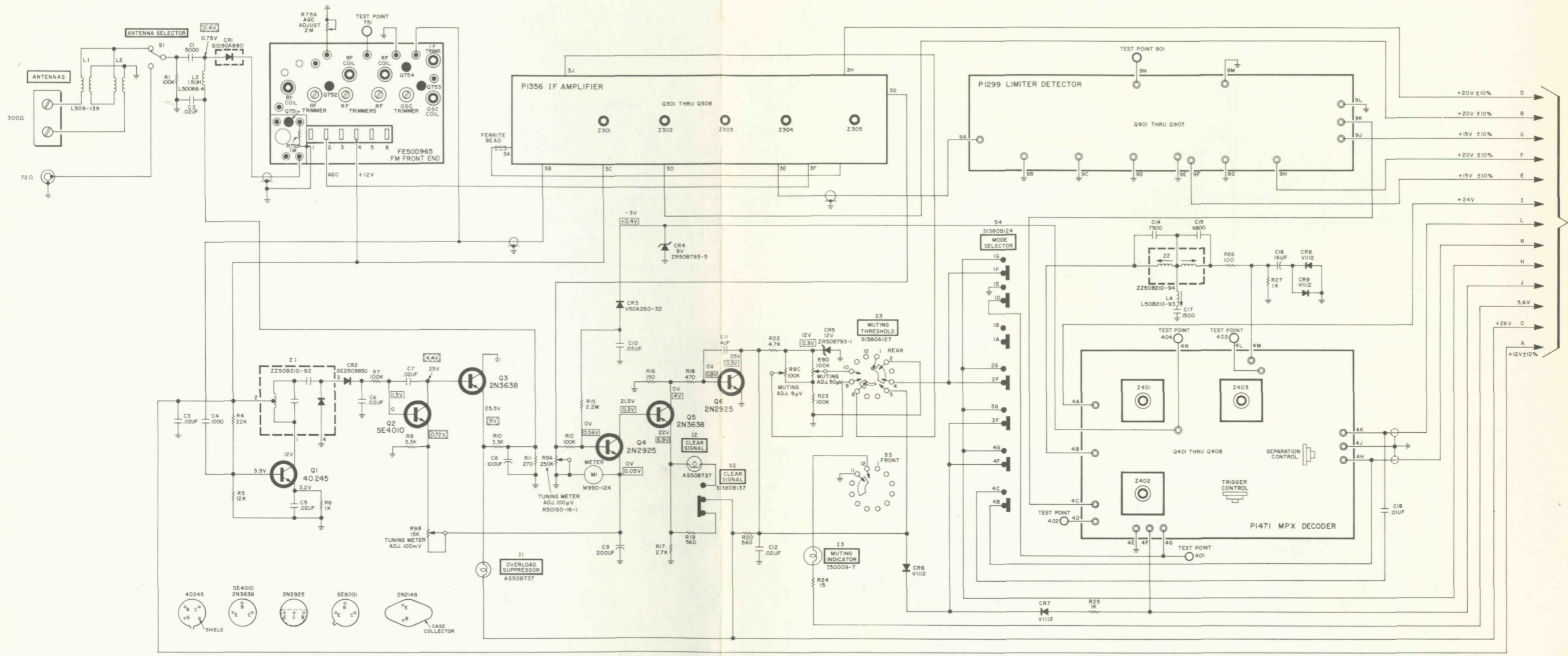

AW2462A

MAIN CHASSIS

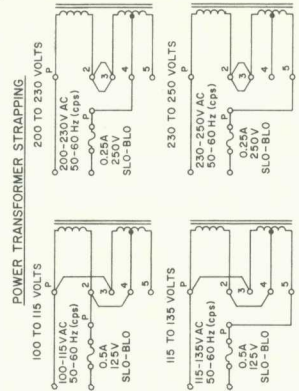
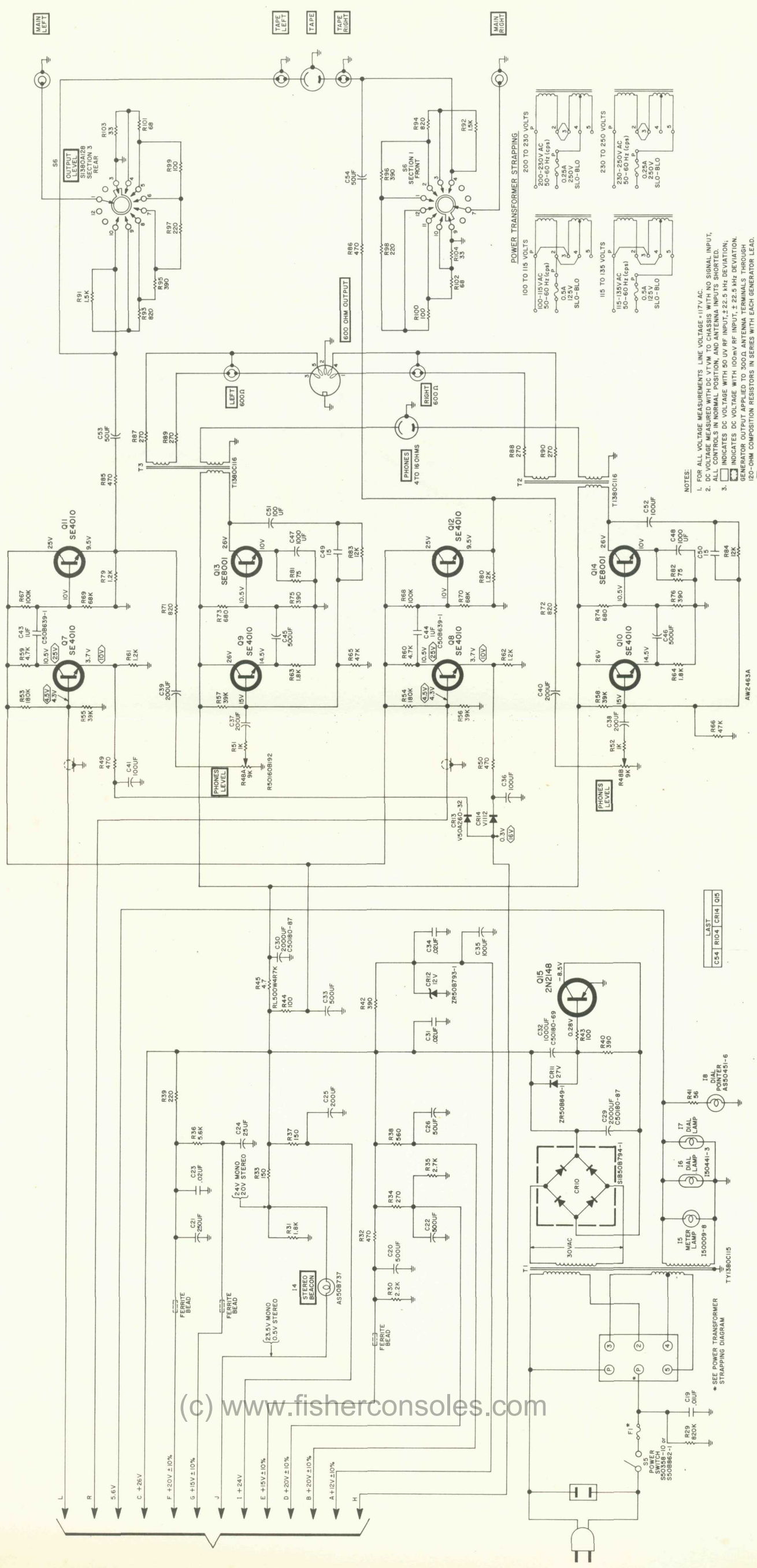

- NOTES:**
1. FOR ALL VOLTAGE MEASUREMENTS LINE VOLTAGE = 117V AC.
 2. ALL CONTROLS IN NORMAL POSITION AND INPUTS SHORTED.
 3. INDICATES DC VOLTAGE WITH 50.0V RF INPUT, ± 22.5 kHz DEVIATION, GENERATOR OUTPUT APPLIED TO 500.0 ANTENNA TERMINALS THROUGH 120-OHM COMPOSITION RESISTORS IN SERIES WITH EACH GENERATOR LEAD.
 4. ○ INDICATES DC VOLTAGE WITH MUTING THRESHOLD SWITCH SET TO THE 1 OR 2 POSITION.
 5. FISHER PART NUMBER LISTED FOR PARTS SPECIALLY SELECTED FOR FISHER RADIO CORPORATION.

(c) www.fisherconsoles.com

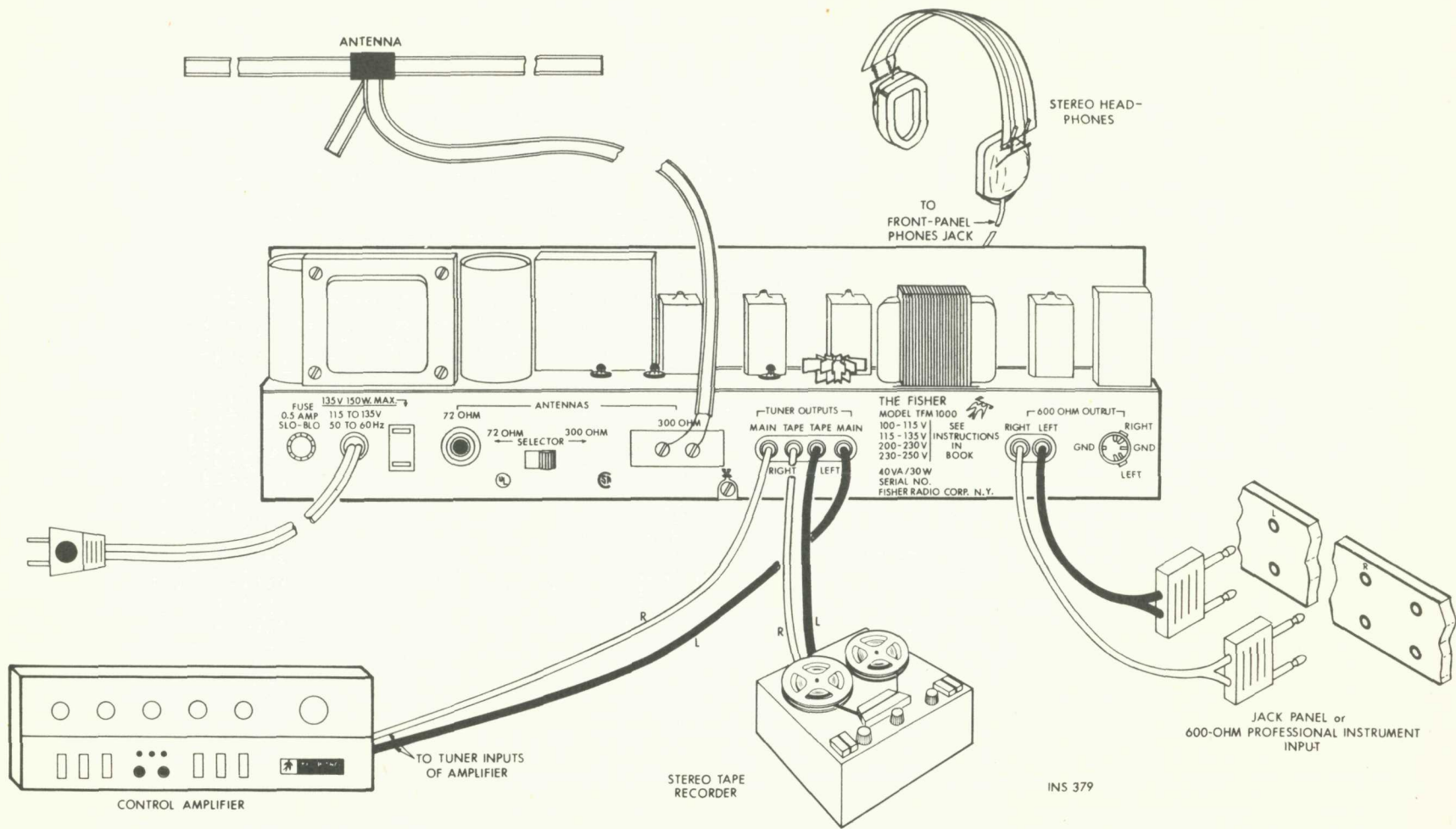

COMPONENT CONNECTIONS

CHASSIS LAYOUT

TOP

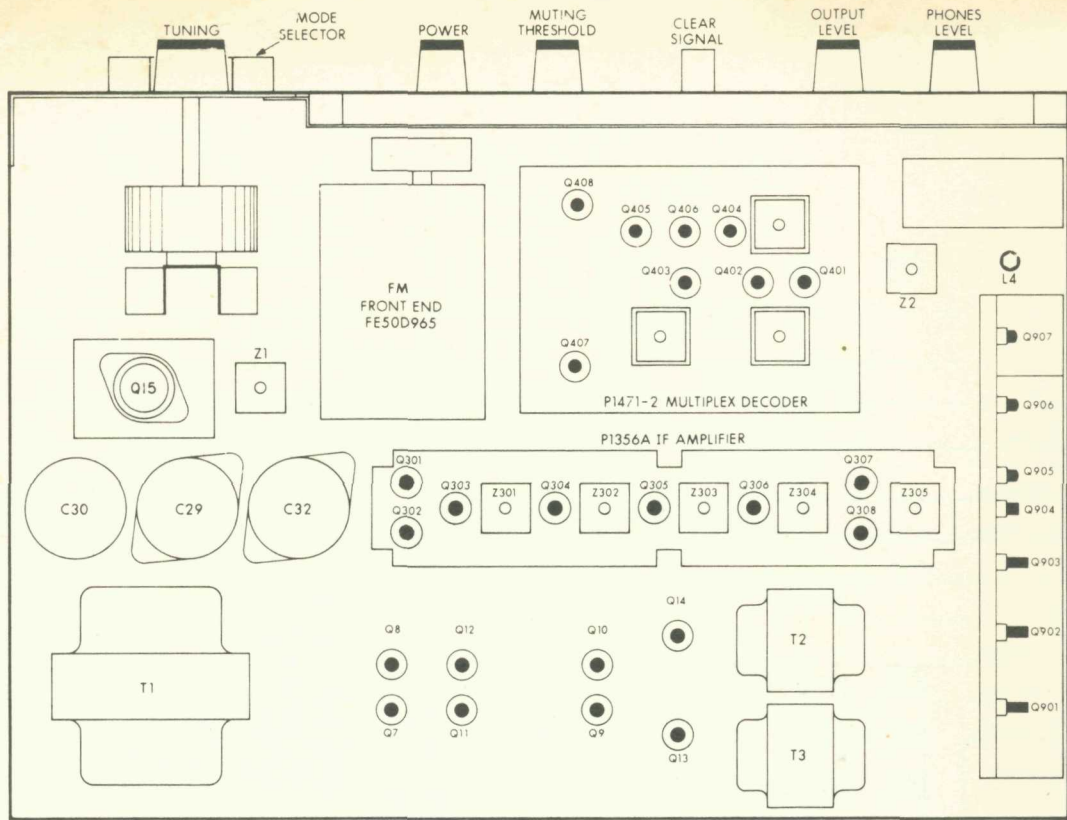

INS 351

BOTTOM

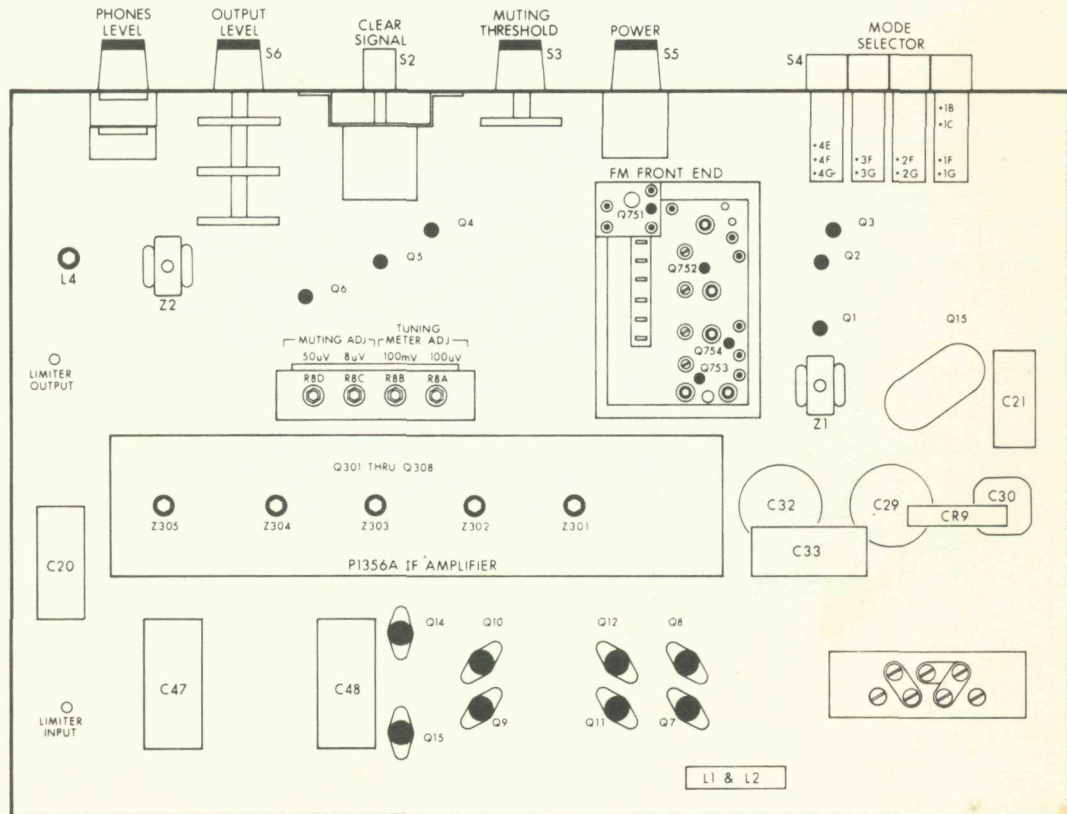

INS 352

FISHER RADIO CORPORATION • NEW YORK

